

FRESH WATER DRAIN
 FUEL OVERFLOW Ø8
 FUEL INLET Ø8

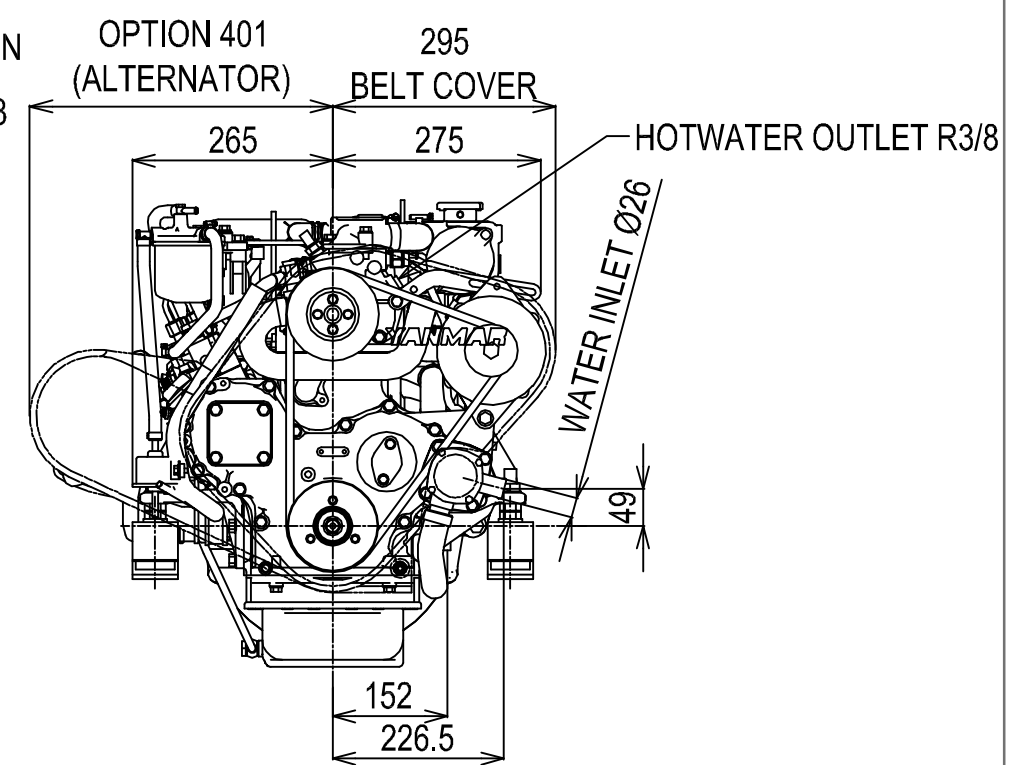

DETAIL OF COUPLING

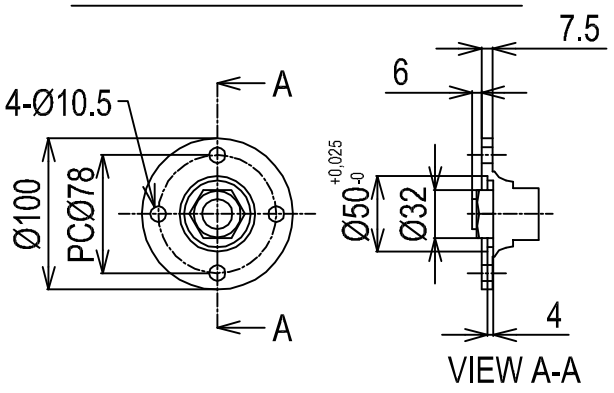

DIRECTION OF ROTATION

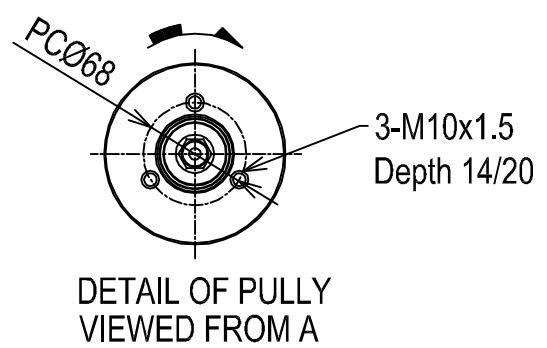

DETAIL OF MOUNTING BLOCK

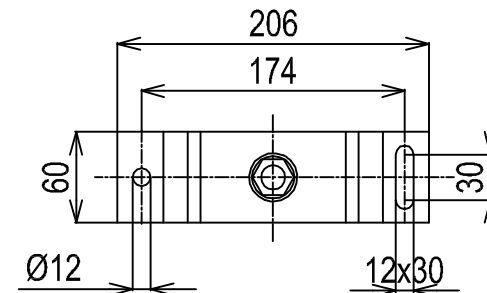

NOTE:

1. DWG. SHOWS MOUNTING BLOCKS AT ORIGINAL HEIGHT. ENGINE WEIGHT WILL COMPRESS BLOCKS BY 4MM (APPROX).
2. MOUNTING BLOCKS ARE EQUIPPED FOR STANDARD ACCESSORY.
3. ● SHOWS THE CENTER OF GRAVITY.
4. THE FIGURES MARKED WITH * SHOW THE DIMENSIONS WITH U-MIXING ELBOW, OR OPTIONAL COUPLING.
5. FOR ADDITIONAL INSTALLATION INFORMATION AND SPECIFICATIONS PLEASE REFER TO THE YANMAR ENGINE INSTALLATION MANUAL

Series: JH5E	Engine: 4JH5ExKM35A2	Release: R2009-01
Scale: 1:10	Date: 01-12-2009	Dimensions: mm

